



Hangcha Europe GmbH

Mariechen-Graulich-Straße 12a,
65439 Flörsheim am Main,
Germany

Tel: 0049-61453769188
E-mail: admin@hangchaeurope.com

Mob: 0049-16096548808 (Thomas Dittrich)
E-mail: thomas.dittrich@hangchaeurope.com
Zip Code Area (1,2,3,4,5,6,7)

Mob: 0049-1605272481 (Jens Abmuth)
E-mail: jens.assmuth@hangchaeurope.com
Zip Code Area (0,8,9)

www.hangchaeurope.com



Follow us on
Instagram



Follow us on
Facebook



Follow us on
YouTube



Download "Hangcha
Forklift" App



ISO14001
ISO14001:2015



ISO9001
ISO9001:2015



HANGCHA trucks conform
to the European Safety
Requirements.

2021 VERSION 1/COPYRIGHT 2021/05

HANGCHA GROUP CO., LTD. reserves the right to make any changes without notice concerning colors, equipment, or specifications detailed in this brochure, or to discontinue individual models. The colors of trucks, delivered may differ slightly from those in brochures.



A Series Rider Pallet Truck

with capacities of 2,000 to 3,000kg

The World of Hangcha



LET THE LITHIUM POWER UNLEASH



INNOVATIVE SOLUTIONS NEW POWER NOW

Innovative, reliable lithium-ion technology (Lithium Iron-Phosphate), which are developed jointly by HANGCHA and CATL. Battery cells and modules are from CATL, with reliable quality, exclusively for HANGCHA.

- / We use square lithium iron phosphate batteries and modules used in large quantities by commercial vehicles in mature economies.
- / The module uses an aluminum alloy frame which is sturdy, lightweight and with excellent heat dissipation.
- / Safe and effective: Charging efficiency as high as 98%, thermal runaway temperature 600 °C or above.
- / Adapted to low temperatures: Comes standard with an electrical heating feature, ensuring normal operation in low temperatures.
- / Quick charging: 2 hours full charge, economic use of each break.
- / Long-working: 4000 charging cycles, capacity retention greater than 80%.
- / Maintenance-free: Battery does not require manual maintenance.
- / Green and clean: Pollution-free, zero emissions.

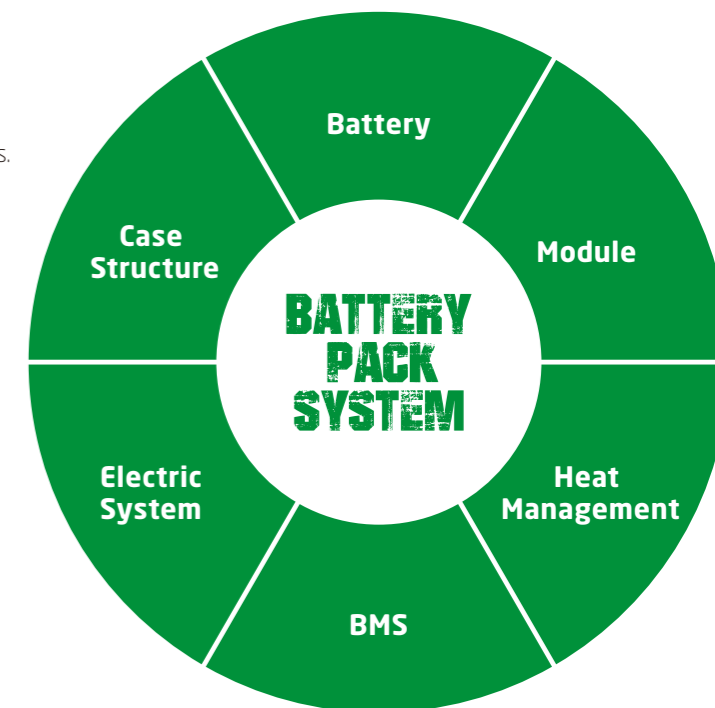

Li-Ion
2 hours
100%

Lead-acid batteries
8-10 hours 100%

Rapid charging and opportunity charging ensure continuous availability of vehicles.

Li-Ion powered forklifts are always available. They allow for fast full charging or boost charging (100 % charge in 2 hours). They are maintenance free and do not require a battery change when used for multi-shift operations.

Li-Ion Battery Pack specification

Type		CBD20-ABC15-ISU	CBD30-ABC15-ISU	CBD20-AC15-ISU	CBD30-AC15-ISU
Li-Ion battery	V/Ah	24/120	24/120	24/120	24/120
Li-Ion battery,Optional	V/Ah	24/202	24/202	24/202	24/202
Titans charger		SPC-24100	SPC-24100	SPC-24100	SPC-24100



HANGCHA provides Li-Ion battery (LiFePO4) with 5 years or 10000 hours warranty.



**5 YEARS
WARRANTY**

A series rider pallet truck

The rider pallet truck is one of the A series pallet truck models. Using the latest AC drive technology, advanced performance, comfort, safe, reliable, low maintenance cost, is the ideal tool for heavy duty and long distance transport operations.

Environment/ Efficiency/ Economy

Appearance

- / A series electric rider pallet truck applied professional industrial design, stream lines, and compact, and fully ergonomic consideration, in line with the latest design trends.
- / Applied steel stamping and injection molding processes for front and back guard, which is robust, durable, and also environmental compliance.



Reliability

- / Adopted unique floating suspension system ensures good driving wheels' grip and excellent stability.
- / Imported waterproof connectors, all wires and cables are protected, greatly improve the reliability of the electric system.
- / Using non-contact proximity switch, improves safety and reliability.
- / Top quality hydraulic power unit applied to provide low noise, low vibration, smooth lifting and landing reliable operation.
- / Punch formed forks to provide more strength and tip guide to provide higher efficient operation.
- / The power plug is fixed on the truck body to avoid damage from battery installment.

Safety

- / Automatic deceleration during turning.
- / Punch-formed frame provide more safety to the operator.
- / Three braking system of regenerative braking, reverse current braking, parking brake, insures the safe operation.
- / Anti-slope on gradient can keep the safety.
- / The braking button on the tiller head can effectively avoid the harm to the driver.
- / The standard equipped electronic lifting limitation protect the pump motor from damaging dramatically and more energy saving.
- / Displayed turtle speed function applied to move slowly and helps to stack goods in narrow space.

Comfort

- / Smooth driving and more comfortable operating experience thanks to a new design of the floating drive suspension system.
- / The compact body and semicircular design provide an ideal operation in limited space, and the wedge designed chassis greatly increases the passing ability.

Maintenance

- / AC motor without carbon brushes, maintenance-free, cost saving.
- / Integrated battery indicator, hour meter and self-diagnostic instrument.
- / Full opened hood, easy accessibility of all components, is easy for service.
- / All shafts installed lubricated shaft sleeve and oil cup, provide convenient maintenance and long service life.



The pedal applies shock absorption design, greatly improve the operator's comfort, reduce the fatigue



Optimized designing structure to offer a good visibility and easy entrance of the pallet

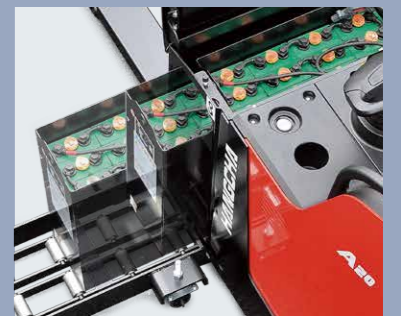

Side battery change is standard feature



Simple and beautiful tiller designed to make the operator feel comfortable, all the operation can be completed by one hand

5-pivot with low centre of gravity design and high strength steel frame structure chassis provide larger residual load capability and longer working life.

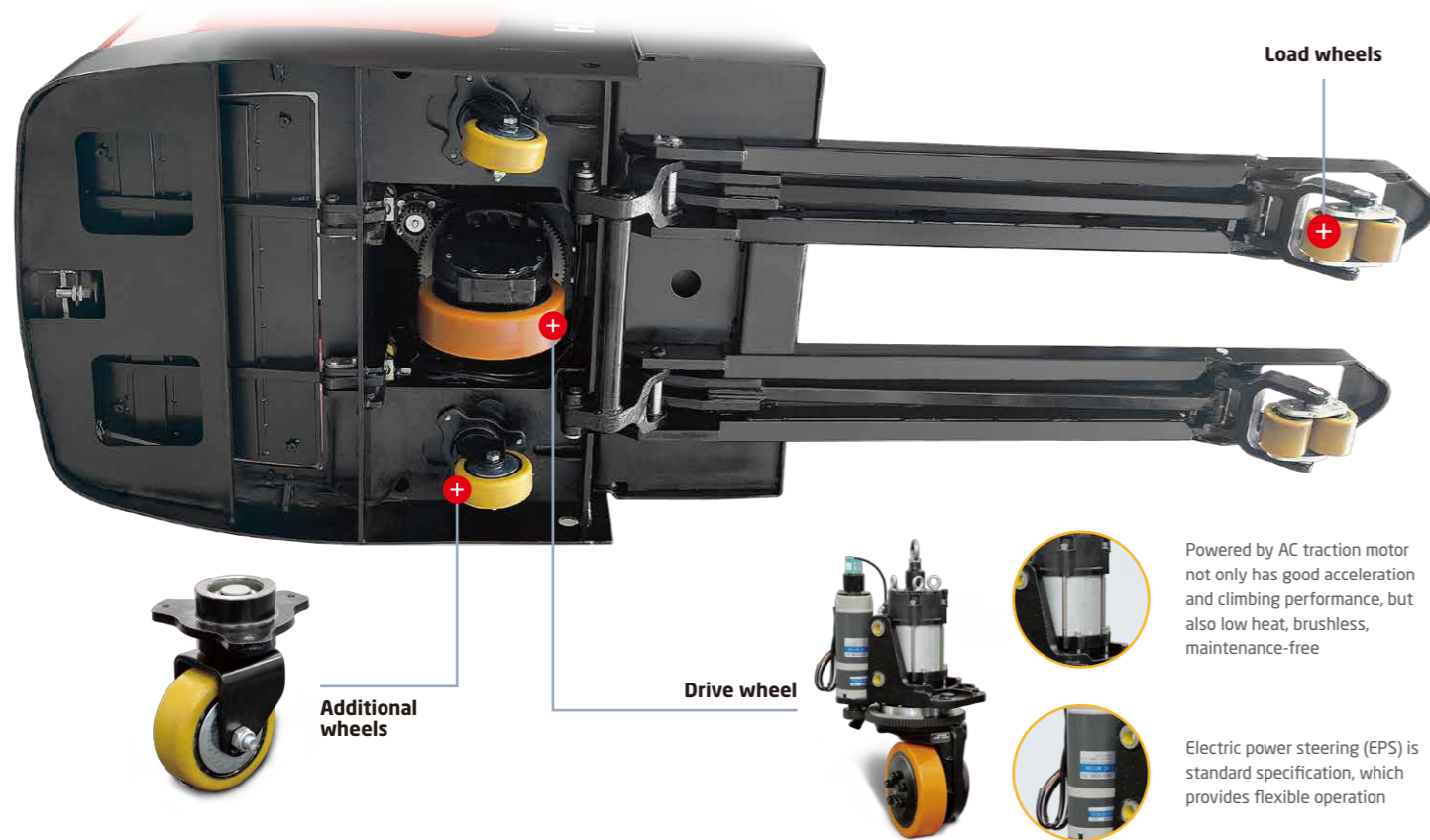

Powered by AC traction motor not only has good acceleration and climbing performance, but also low heat, brushless, maintenance-free

Electric power steering (EPS) is standard specification, which provides flexible operation

High Performance

- / Electric power steering (EPS) is standard specification, which provides flexible operation.
- / Powered by AC traction motor not only has good acceleration and climbing performance, but also low heat, brushless, maintenance-free.
- / Latest AC control system, precise and smooth.
- / CAN-BUS connection enables all truck data can be read out for inspection, and also improves the data transition more quick and reliable.
- / Regenerative braking for battery recovery during travel speed reduction, anti-slope on gradient.
- / All key parts such as switches, connectors, battery indicator and hour meter all adopt the famous brand.

Standard specification

- / AC drive motor
- / AC controller
- / Electric Power Steering (EPS)
- / Emergency switch
- / 1150mm fork length
- / Side battery change
- / Multi-function battery indicator
- / CAN-bus technology
- / 540mm outside fork width
- / Automatic speed reduction when cornering
- / Imported hydraulic unit
- / Brake switch

Options

- / Different length of fork
- / Different capacity of battery

A Series Rider Pallet Truck

Distinguishing mark	HANGCHA GROUP CO.,LTD.					
	1.1	1.2	1.3	1.4		
1.1	Manufacturer					
1.2	Manufacturer's type designation	CBD20-ABC1S-SU CBD20-ABZ3S-SU	CBD20-AC1S-SU CBD20-AZ3S-SU	CBD30-ABC1S-SU CBD30-ABZ3S-SU		
1.3	Drive: electric (battery or mains), diesel, petrol, fuel gas	Electric	Electric	Electric		
1.4	Operator type: hand, pedestrian, standing, seated, order-picker	Standing	Standing	Standing		
1.5	Rated capacity/rated load	Q (kg) 2000	2000	3000		
1.6	Load centre distance	c (mm) 600	600	600		
1.9	Wheelbase	y (mm) 1505	1505	1505		
Weight	2.1	Service Weight	kg 825	880	880	920
Tyres, chassis	3.1	Tyres: solid rubber, superelastic, pneumatic, polyurethane	PU	PU	PU	PU
	3.2	Tyre size, front	ø85×80	ø85×80	ø85×80	ø85×80
	3.3	Tyre size, rear	ø230×75	ø230×75	ø230×75	ø230×75
	3.4	Additional wheels (dimensions)	ø125×50	ø125×50	ø125×50	ø125×50
	3.5	Wheels, number front / rear (x = driven wheels)	1×+2/4	1×+2/4	1×+2/4	1×+2/4
	3.6	Tread, front	b ₁₀ (mm) 575	575	575	575
	3.7	Tread, rear	b ₁₁ (mm) 370	370	370	370
Dimensions	4.3	Free lift	h _z (mm) 125	125	125	125
	4.19	Overall length	l ₁ (mm) 2372	2372	2372	2372
	4.21	Overall width	b ₁ (mm) 800	800	800	800
	4.22	Fork dimensions ISO 2331	s/e/l (mm) 64/170/1150	64/170/1150	64/170/1150	64/170/1150
	4.25	Distance between fork-arms	b _s (mm) 540/680	540/680	540/680	540/680
	4.31	Ground clearance, laden, below mast	m ₁ (mm) 21	21	21	21
	4.34.1	Aisle width for pallets 1000 x 1200 crossways	A _{st} (mm) 2504 ¹⁾	2504 ¹⁾	2504 ¹⁾	2504 ¹⁾
	4.34.2	Aisle width for pallets 800 x 1200 lengthways	A _{st} (mm) 2554 ²⁾	2554 ²⁾	2554 ²⁾	2554 ²⁾
4.35	Turning radius	W _a (mm) 2134 ³⁾	2134 ³⁾	2134 ³⁾	2134 ³⁾	
Performance data	5.1	Travel speed, laden/unladen	km/h 6.5/7.0	9.0/9.5	5.5/7.0	7.5/9.5
	5.2	Lift speed, laden/unladen	m/s 0.047/0.064	0.047/0.064	0.036/0.053	0.036/0.053
	5.3	Lowering speed, laden/unladen	m/s 0.075/0.071	0.075/0.071	0.060/0.058	0.060/0.058
	5.8	Max. gradeability, laden/unladen	% 5/16	8/16	5/16	8/16
	5.10	Service brake	Electromagnetic	Electromagnetic	Electromagnetic	Electromagnetic
Electric engine	6.1	Drive motor rating S2 60 min	kW 1.5	2.2	1.5	2.2
	6.2	Lift motor rating at S3 15%	kW DC 2.2	DC 2.2	DC 2.2	DC 2.2
		Steering motor	kW DC 0.2	DC 0.2	DC 0.2	DC 0.2
	6.4	Battery voltage, nominal capacity K5 (Lead-acid)	V/Ah 24/240	24/280	24/280	24/340
		Battery voltage, rated capacity, Optional	V/Ah 24/-340	24/-340	24/-340	-
	8.1	Type of drive unit	AC traction	AC traction	AC traction	AC traction
	9.1	Manufacturer/Type	CURTIS/ZAPI	CURTIS/ZAPI	CURTIS/ZAPI	CURTIS/ZAPI
	10.7	Sound pressure level at the driver's seat	dB (A) ≤75	≤75	≤75	≤75

Note: 1). VDI 2198: +430mm 2). VDI 2198: +236mm 3). When fork lowered,+68mm

